

COMMERCIAL PUMP

Owners Manual

Installation and Operation



⚠ WARNING

This pool pump must be installed and serviced by a qualified pool/ spa technician in accordance with all applicable codes and ordinances. Improper installation can create electrical hazards which could result in death, serious injury, or property damage. Improper installation will void the warranty.



Notice to Installer

This manual contains important information about the installation, operation and safe use of this product. Once the product has been installed **this manual must be given to the owner/ operator of this equipment.**

Table of Contents

- INTRODUCTION** ----- 01
- SAFETY INFORMATION** ----- 02
- INSTALLATION** ----- 04
 - Receive and Check Pump ----- 04
 - Lifting and Handling ----- 04
 - a) Hydrostar Pump Procedure ----- 04
 - b) Hydrosteel Pump Procedure ----- 04
 - c) Cast Iron Pump Procedure ----- 05
 - Pump Location ----- 06
 - Piping Design and Installation ----- 06
 - Piping Installation Guide ----- 07
 - Electrical Installation ----- 07
 - Three Phase Connections ----- 08
 - Electrical Installation Guide ----- 09
- START-UP** ----- 10
 - Start-up procedure ----- 10
- MAINTENANCE** ----- 11
 - Strainer Basket Cleaning ----- 11
 - Winterizing ----- 12
 - Electric Motor Care ----- 13
- TROUBLESHOOTING** ----- 14
- PUMP PERFORMANCE CURVES** ----- 15
- PUMP DIMENSION DRAWINGS** ----- 17
- WARRANTY** ----- 21

PUMP INSTALLATION RECORD	
Pump Model No:	Pump Serial no:
Date of Purchase:	Purchased from:
Installed by:	Installer Phone No:
Notes:	

INTRODUCTION

Congratulations on choosing a Waterco Commercial pump. This manual contains information pertaining to the installation, operation and maintenance of your Commercial pump. Please read the instructions in this manual carefully.

All Waterco equipment is designed and manufactured to give many years of safe and reliable operation. We hope that you obtain the maximum pleasure and benefit from your new pump!

IMPORTANT SAFETY INSTRUCTIONS

When installing and using electrical equipment, basic safety precautions should always be followed. This includes the following:

READ AND FOLLOW ALL INSTRUCTIONS

⚠ DANGER

Do not block the pump suction; this can cause severe or fatal injury if blocked with the body.

⚠ WARNING

To reduce the risk of injury, do not permit children to use this product unless they are closely supervised at all times.

⚠ WARNING

Risk of Electric Shock: connect only to a grounding type receptacle protected by a residual current device (RCD). Contact a qualified electrician if you cannot verify that the receptacle is protected by an RCD.

⚠ WARNING

Do not bury the electrical cable. Locate the cable in a manner that minimises abuse from lawn mowers, hedge trimmers, and other equipment.

⚠ WARNING

To reduce the risk of electric shock, replace damaged cable immediately.

⚠ WARNING

Incorrectly installed equipment may fail, causing severe injury or property damage.

⚠ WARNING

Equipment that is incorrectly pressure tested may fail, causing severe injury or property damage. Pressure testing should only be conducted by trained pool professionals.

⚠ WARNING

Do not change the multiport valve position when the pump is running.

⚠ CAUTION

This pump is for use with permanently installed pools and may also be used with hot tubs and spas if so marked. Do not use with storable pools. A permanently installed pool is constructed in or on the ground or in a building such that it cannot readily be disassembled for storage. A storable pool is constructed so that it may be readily disassembled for storage and reassembled to its original integrity and has a maximum dimension of 18 feet (5.49m) and a maximum wall height of 42 inches (1.07m).

⚠ CAUTION

To prevent overheating, do not install the pump within an enclosed area unless adequate ventilation is provided.

⚠ CAUTION

Do not start the pump dry! Running the pump dry for any length of time will cause severe damage and will void the warranty.

⚠ WARNING

Chemical fumes and spills can weaken pool/spa equipment. Corrosion can cause pumps, filters and other equipment to fail, resulting in severe injury or property damage. Do not store pool chemicals near your equipment.

READ AND FOLLOW ALL INSTRUCTIONS

INSTALLATION

Receive and Check Pump

Check the pump packaging for damage. Check for shipping damage such as dented, cracked or bent parts. If damage is detected contact the shipper or distributor from which the pump was purchased.

Lifting and Handling

⚠ WARNING

Crushing Hazard. NEVER walk or reach under a suspended pump.

a) Hydrostar Pump Procedure

The Hydrostar Pumps can be lifted and carried manually. The larger units will require two people to move and position the pump into place.

b) Hydrosteel Pump Procedure

The eye bolt built into the motor body is not designed to support the combined weight of the motor and pump body. DO NOT attempt to lift the pump by attaching a clip to this eye bolt.

Use a minimum of two chains or straps to support the entire motor and pump. The crane or hoist used, as well as each individual chain or strap, must have a weight-bearing capacity in excess of the combined weight of the motor and pump.

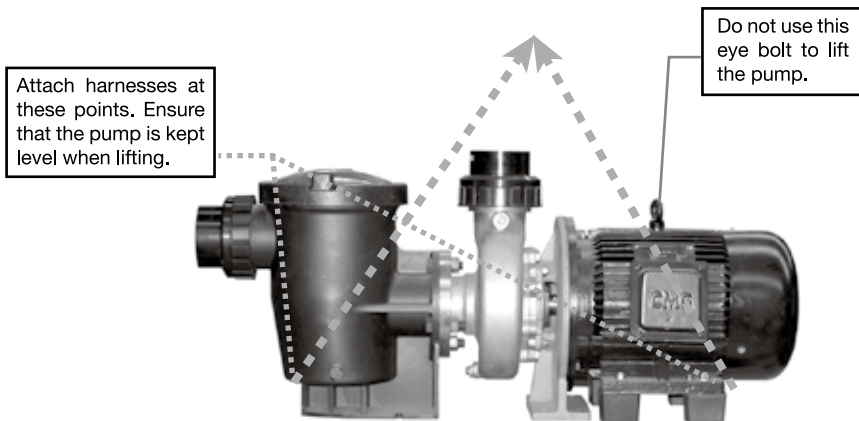

c) Cast Iron Pump Procedure

The eye bolt built into the motor body is not designed to support the combined weight of the motor and pump body. DO NOT attempt to lift the pump by attaching a clip to the eye bolt.

Use a minimum of two (preferably three) chains or straps to support the entire motor and pump. The crane or hoist used, as well as each individual chain or strap, must have a weight-bearing capacity in excess of the combined weight of the motor and pump.

For models where the wet end is made out of a composite material instead of cast iron – DO NOT place any straps under the wet end for lifting – this will cause the wet end to crack. In these scenarios – place the lifting strap under the pump housing.

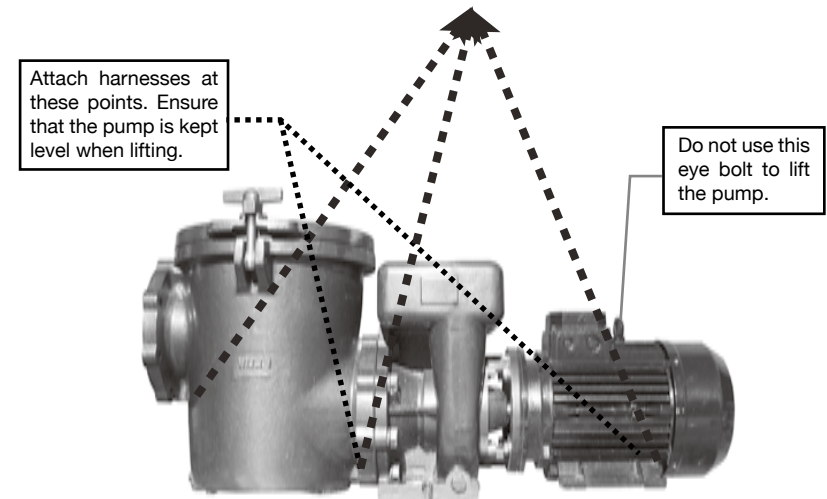

Lifting Procedure

- i) Raise the pump slowly to ensure that the chains or straps will not slip when under tension.
- ii) Check that the pump is properly balanced when it is raised. If it is not, release the tension on the chains or straps and readjust their position.

Pump Location

- a) The pump should be located in a position that enables easy access for periodic servicing. Leave the area above the pump lid clear for removal of the basket for cleaning.
- b) The pump and other circulation equipment must be located a minimum of 1.5m (5ft) from the water.
- c) The pump elevation should not be more than a few feet above the water level of the pool; it is recommended that the pump be located within 0.30m (1ft) of the water level. A Waterco check valve is recommended on the pump suction piping.
- d) If the pump is installed below water level, shut off valves (either Waterco diverter or ball valves) should be installed on both the suction and discharge piping to prevent back flow of pool water during routine servicing of the pump and other circulation equipment.
- e) Place the pump on a solid foundation that will not vibrate. It is suggested that the pump be bolted down to reduce noise from vibration.
- f) The pump foundation must have adequate drainage to prevent the motor from being flooded.
- g) Protect the pump from the sun and rain.
- h) Install the pump in a well-ventilated area – ensure there is enough clearance around the motor and fan cowl.

If the pump is installed under cover, provide adequate ventilation and lighting.

Piping Design and Installation

Both the suction and discharge lines should have a minimum pipe size as follows:

- a) Hydrostar Mk3
 - 80mm inlet and outlet
- b) Hydrosteel Pump
 - 80mm inlet and outlet
- c) Cast Iron Pump
 - 150mm at the inlet and 100mm at the outlet

Piping Installation Guide

- a) Use only the pump barrel unions that are supplied with the pump.
- b) The piping must be well supported to reduce piping load on the equipment and excess stress on the piping.
- c) To reduce difficulty in priming, install suction piping without high points that can trap air. If the circulation equipment is located more than 30m (100ft) from the water, increase the piping diameter to the next size.
- d) Install the piping with the least number of bends (elbows) and fittings.
- e) Every new installation must be pressure tested according to local codes.

WARNING

Do not pressure test the pump above 35 psi. Pressure testing must be done by a trained pool professional. Circulation equipment that is not properly tested may fail, resulting in severe injury or property damage.

Electrical Installation



WARNING RISK OF ELECTRIC SHOCK

This pool pump must be installed by a licensed or certified electrician or serviceman in accordance with all applicable local codes and ordinances. Improper installation can create electrical hazards, which could result in death, serious injury or damage to property. Always disconnect power to the pool pump at the circuit breaker before servicing the pump. Failure to do so could result in death or serious injury to servicemen, pool users or others due to electric shock.

Three Phase Connections

Three phase connections should be installed as follows:

- a) Hydrostar Mk3: WYE/STAR CONNECTION
- b) Hydrosteel: DELTA CONNECTION
- c) Cast Iron: DELTA CONNECTION



Check that the information on the nameplate corresponds to the power supply.

Every motor requires either a **fused disconnect switch** or a **circuit breaker**.

A separate device must be available for permanent installation so the pump can be isolated from the mains power. **A contact distance of at least 3mm per pole is required for three phase units.**

Three Phase Motors require a starter switch or magnetic starter with correctly sized overload protection in addition to the fused disconnect switch.

Check The Rotation Of Three Phase Motors. The motor is only suitable for clockwise operation when viewed from the motor end fan (cowl) cover.

Three phase motors could rotate in either direction. Interchanging any 2 cables on a three phase motor will reverse the direction of rotation. To check the rotation of the motor, turn on for approximately 1 second. If it is running in the wrong direction turn off power, interchange the wiring and repeat the above step to check.

The installer must protect all three phases on the supply of the motor so that the pump cannot run on 1 or 2 phases only. An external current limiting device must be installed to protect the motor in the event of a phase drop out.

If the pump is to be used for a swimming pool situation, it is **MANDATORY** that an earth circuit breaker with a rated tripping current not exceeding **30mA** be installed.

Motor protection **MUST** be installed corresponding to the nominal current of the motor. **SEE VALUE ON RATING PLATE.**

It is the **RESPONSIBILITY** of the user to ensure that there is adequate protection between the motor and the power supply.

Electrical Installation Guide

- a) Make sure all electrical breakers and switches are turned off before wiring the motor.
- b) Make sure that the wiring voltage matches the motor voltage. If they do not match the motor will be damaged.
- c) It is the responsibility of the electrical installer to provide data plate operating voltage and current to the pump by ensuring proper circuit and wire sizes.

⚠ WARNING

Failure to provide data plate voltage (within 10%) during operation will cause motor overheating and will void the warranty.

- d) Make sure all electrical connections are clean and tight.
- e) Cut wires to the appropriate length so they don't overlap or touch when connected to the terminal board.
- f) Permanently ground the motor using the green ground terminal located on the inside of the motor canopy or access plate. Use the correct wire size and type specified by local codes.
- g) Make sure the ground wire is connected to an electrical service ground. Bond the motor to the pool structure in accordance with the National Electrical Code. Use a solid No.8 AWG or larger copper conductor. Run a wire from the motor external bonding to the pool bonding structure.
- h) Connect the pump permanently to a dedicated circuit. No other lights, equipment, or appliances can be used on the same circuit.

⚠ WARNING

Install the control switch or time clock well away from the pool pump, filter, and other equipment. Should there be an equipment failure or loose fitting, access to the switch away from the failed equipment is important.

START-UP

These pumps are designed to be used in pool recirculation systems with water at temperatures above 0°C (32°F) and not exceeding 40°C (104°F). Please refer to the Waterco Warranty Terms and Conditions booklet supplied with the pump.

⚠ CAUTION

Never run the pump without water. Running the pump dry for any length of time can cause severe damage to the mechanical seal, pump and motor. Maintain the water level in your pool half way up the skimmer opening. If the water level falls below the skimmer opening, the pump will draw air through the skimmer. This will cause the pump to lose prime and run dry.

Start-up procedure

- a) Clear all piping of construction debris and verify that the piping has passed a proper pressure test.
- b) Check the filter and other equipment for proper installation, verifying all clamps and connections are properly installed as per the manufacturer's instructions.
- c) Open any shut off valves on the suction and discharge lines.
- d) Open the filter pressure relief valve and release all pressure from the system.
- e) If the pump is located below the water level of the pool, opening the pressure relief valve will fill the pump with water.
- f) If the pump is located above the pool water level, remove the lid from the strainer pot and fill the basket with water before starting the pump.
- g) Check to see that the lid O-ring and seat areas are clean and lubricated. Debris in the sealing area can cause air to leak into the system and make it difficult to prime the pump. Use a silicone based lubricant.
- h) Close/tighten the lid to make an airtight seal.
- i) Turn on the pump.
- j) Bleed air from the filter until a steady stream of water comes out. Close the air relief valve.
- k) If the pump does not prime and all instructions to this point have been followed, check for suction leaks and repeat steps (b) through (j).

⚠ WARNING

High suction lift or long suction line will require additional time to prime and can severely affect the performance of the pump.

MAINTENANCE

⚠ WARNING

DO NOT open the strainer pot if the pump fails to prime or if the pump has been operating without water in the strainer pot. Pumps operated in these circumstances may experience a build up of vapor pressure and may contain scalding hot water. Opening the pump may cause serious personal injury. In order to avoid the possibility of personal injury, make sure the suction and discharge valves are open and strainer pot temperature is cool to touch, then open with extreme caution.

⚠ CAUTION

To prevent damage to the pump and filter and for proper operation of the system, clean pump strainer and skimmer basket regularly.

Strainer Basket Cleaning

- a) Turn off the power to the pump.
- b) Turn the filter MPV to 'Recirculate' before shutting off any valves. This will keep the filter flooded while servicing the pump, and there will be no need to bleed air from the filter after servicing. Revert the MPV back to 'Filter' position after the pump lid is back on and sealed. If the pump is installed below water level, close any shut off valves on the suction and discharge lines.
- c) Relieve pressure in the system.
- d) Turn the clamp and lid in a counter-clockwise direction until it stops. For the Cast Iron Pump - undo and release the toggle bolts.
- e) Lift and remove the clamp and lid set from the wet end of the pump.
- f) Put the debris from the basket into the trash and rinse out the basket.
- g) Replace the basket.
- h) If the pump is located above the pool water level, fill the basket with water.
- i) Clean the lid, lid O-ring, and sealing surface of the pump pot.
- j) Replace the lid by placing the clamp and the lid on the pot. Make sure the lid O-ring is properly placed. Seat the clamp and lid then turn clockwise until the lid is hand tight. **Do not use any tools to tighten the lid.** For the Cast Iron Pump, re-latch and clamp down the toggle bolts
- k) Open all valves on the suction and discharge lines.
- l) If the pump is located below the water level of the pool, the pump will fill with water.
- m) Stand clear of the filter. Turn on the power to the pump.
- n) If the pump does not prime and all instructions to this point have been followed, check for suction leaks and repeat steps (h) through (o).

Winterizing

If the air temperature drops below 0°C (35°F), the water in the system can freeze and cause damage. Freezing damage is not warrantable.

To prevent freezing damage follow the procedures listed below:

- a) Shut off electrical power for the pump at the house circuit breaker.
- b) Drain the water out of the pump case by removing the two drain plugs from the case. Store the plugs in the pump basket.
- c) Cover the motor to protect it from severe rain, snow and ice.
- d) If it is possible, store the pump in a dry location during this time.
- e) Do not wrap the motor in plastic. It will cause condensation and rust on the inside of the motor.
- f) Where possible, have a qualified service technician or electrician disconnect the electrical wiring at the switch or junction box and store the pump indoors.
- g) When the pump is reactivated, ensure all seals and o-rings are in operational condition. If they are not, re-greasing or replacing may be necessary.

CAUTION

In cold climate areas, when temporary freezing conditions may occur, run your filtering equipment all night to prevent freezing.

Electric Motor Care

- a) Protect from heat
 - Shade the motor from the sun.
 - Any enclosure must be well ventilated to prevent overheating.
 - Provide ample cross ventilation.
- b) Protect against contamination
 - Protect from any foreign matter.
 - Do not store (or spill) pool chemicals near the motor.
 - Avoid sweeping or stirring up dust near the motor while it is operating.
 - If a motor has been damaged by dirt it voids the motor warranty.
- c) Protect against moisture
 - Protect from splashing pool water.
 - Protect from the weather.
 - Protect from lawn sprinklers.
 - If a motor has become wet, let it dry before operating. Do not allow the pump to operate if it has been flooded.
 - If a motor has been damaged by water it voids the motor warranty.
- d) Regularly verify:
 - That the mechanical parts and support screws of the pump are correctly attached.
 - The position, attachment and condition of the supply cables and insulating parts.
 - The temperature of the motor.
 - Whether the pump is vibrating abnormally.

CAUTION

DO NOT wrap with plastic or other airtight materials. The motor may be covered during a storm, for winter storage, etc. but never when operating or set up for automatic operation. conditions may occur, run your filtering.

TROUBLESHOOTING

Waterco strongly recommends you have a qualified service technician service your pump. However, many problems may be solved by consulting the table below.

SYMPTOMS	PROBABLE CAUSE	ACTION
1. PUMP WILL NOT PRIME	Suction air leak	Make sure water level is correct through suction points. Ensure baskets and strainers are free of debris. Tighten all fittings/unions on the suction side of the pump, remove and replace mechanical seal.
	No water in the pump	Make sure hair and lint pot is full.
	Closed valves or blocked lines	Open all valve in system, clean skimmer and pump basket, check pump impeller for blockage.
2. MOTOR WILL NOT RUN	No power to motor	Check that all electrical switches are on. Ensure the circuit breakers are properly set. Check if timer is set properly. Check motor wiring at terminals.
	Pump jammed	With power switched off turn pump shaft (should spin freely). If not, contact electrician or nearest Waterco Limited branch for service.
3. LOW FLOW	Dirty filter	Backwash or clean cartridge.
	Dirty Skimmer and Pump strainer	Clean skimmer and pump strainer.
	Suction air leak	See 1.
	Closed valve or blocked line	See 1.
4. MOTOR RUNS HOT	Low or incorrect voltage	Supply to be corrected by electrician. Motors run hot to touch and is normal. Thermal overload protector will function to turn them off if there is an overload or high temperature problem.
	Installed in direct sunlight	Shield from the weather.
	Poor ventilation	Do not tightly cover or enclose motor.
5. NOISY PUMP OPERATION	Bad bearing	Have electrician replace.
	Air leak in suction	See 1.
	Suction blockage	Locate and clear blockage
	Foreign matter in impeller	Dismantle pump and remove foreign matter and debris from around impeller.
	Cavitations	Improve suction, reduce suction lift, reduce number of fittings on suction side, increase pipe size, increase discharge pressure and reduce flow by throttling discharge valve.
6. MOTOR OVERLOAD CUTS OUT	Motor not connected properly	Have electrician check wiring.
	Low incoming voltage	Have electrician check voltage, ensure pump is not running on an extension cord. Report low supply to authorities.
	Overload due to binding in pump or wrong size impeller	Contact Waterco Limited for service.
7. WATER LEAK BETWEEN MOTOR AND PUMP BODY	Damaged or failed mechanical seal	Replace mechanical seal.

⚠ WARNING

If the Waterco Limited pump is within the stated warranty period and you experience faults, always contact your supplier or the nearest Waterco Limited branch for advice. Failure to do this may void the warranty. Refer to warranty documentation supplied with the pump.

All electrical work is to be carried out by a qualified electrician. Under no circumstances should you attempt repairs on the electrical components of Waterco Limited pumps unless you are qualified to do so.

PUMP PERFORMANCE CURVES

Hydrostar Mk3

Hydrostar Mk3 Performance Curves

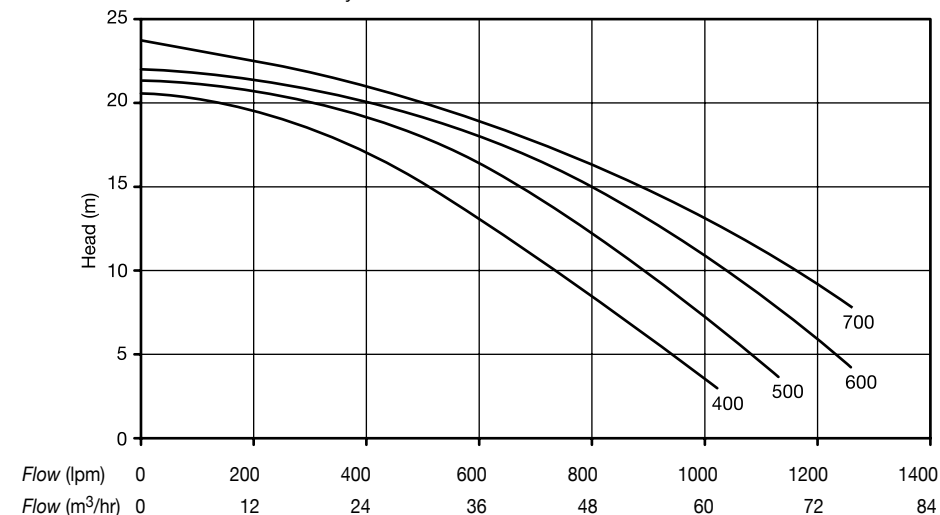

Hydrosteel Pump

Hydrosteel Pump Performance Chart

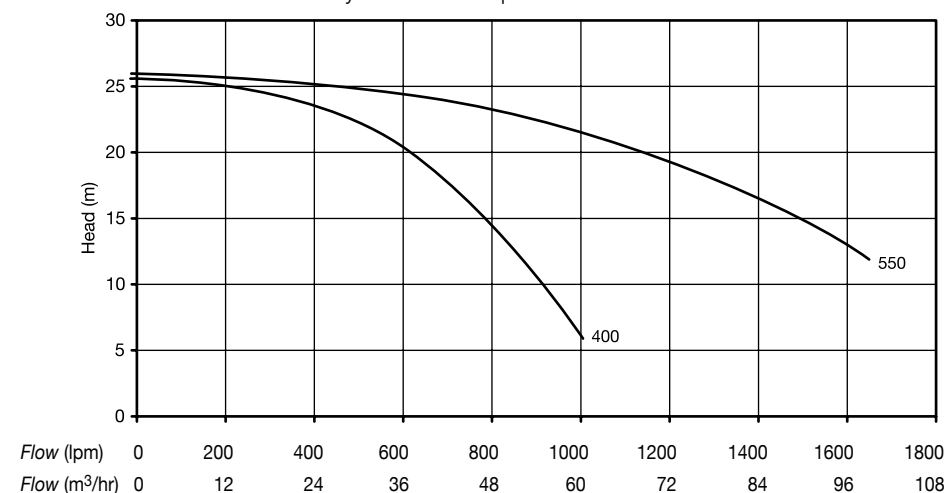

Cast Iron Pump - Australia/New Zealand Market

CI Pump Performance Curves

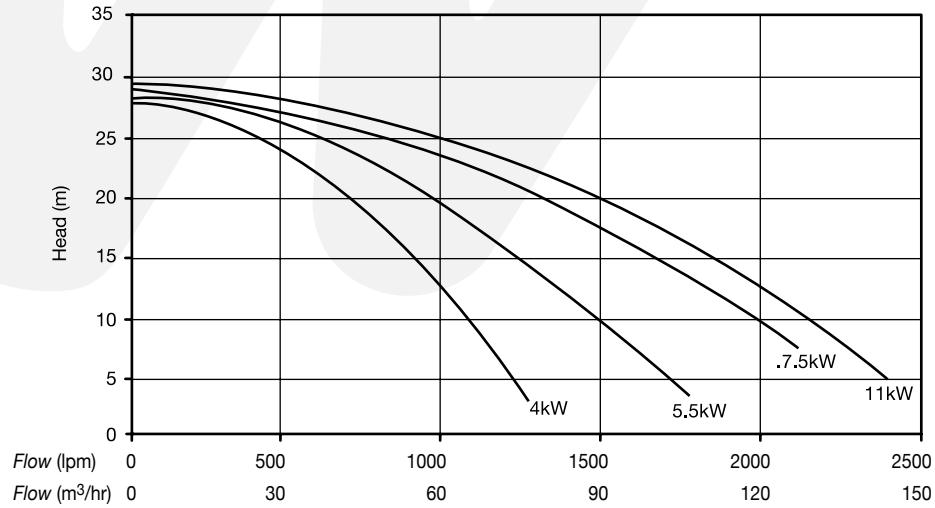

Cast Iron Pump - Europe/Asia Market

CI Pump Performance Curves

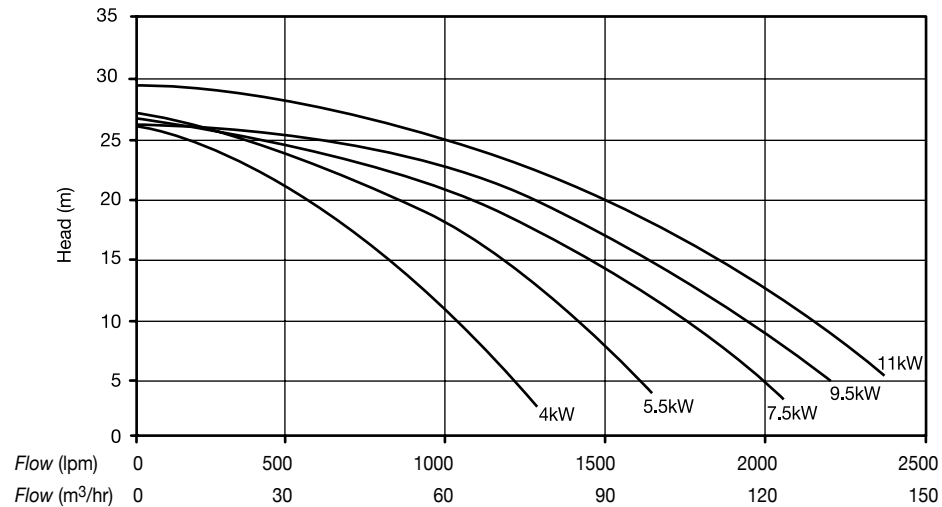

PUMP DIMENSIONAL DRAWINGS

Hydrostar Mk3

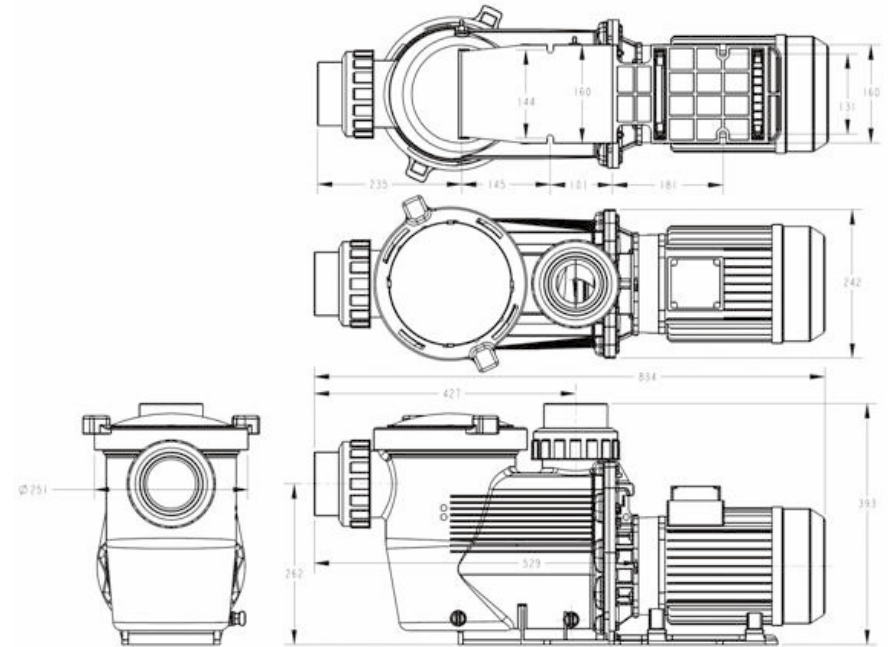

Hydrosteel Pump

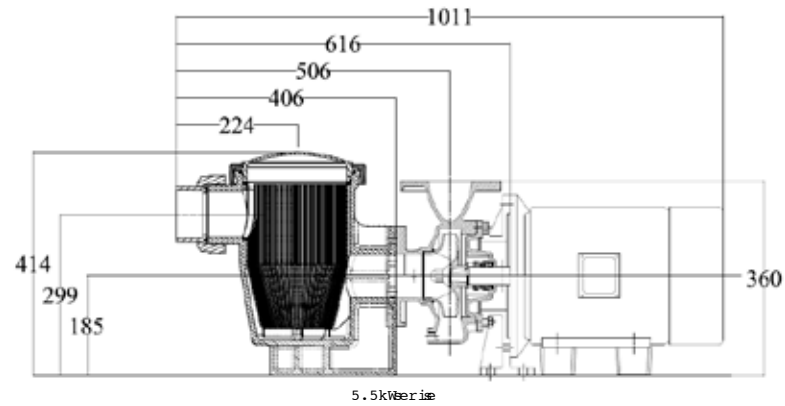
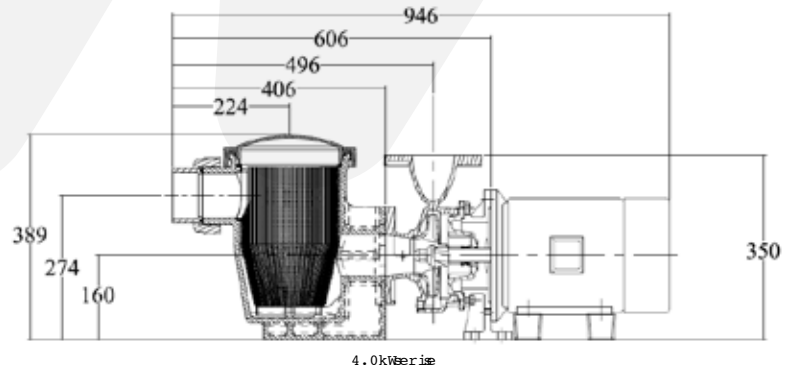

Cast Iron Pump - Australia/New Zealand Market

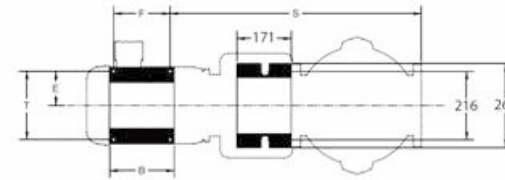

FOOTPRINT DETAIL

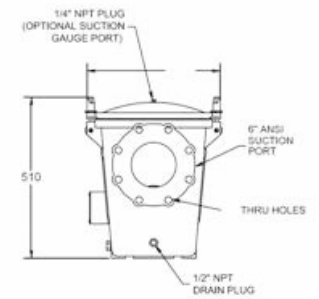
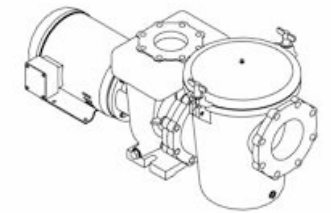
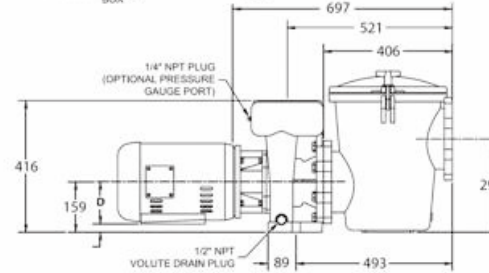
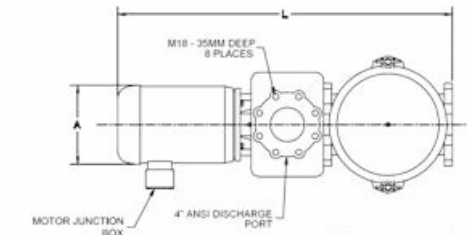

Dimensions - all in mm

	A	B	D	E	F	L	R	S	T	W
4kW	260	180	112	95	140	1017	48	727	190	657
5.5kW	298	200	132	108	140	1070	28	749	216	660
7.5kW	298	200	132	108	140	1070	28	749	216	660
11kW	325	220	160	127	210	1198	0	796	254	688

Cast Iron Pump - Europe/Asia Market

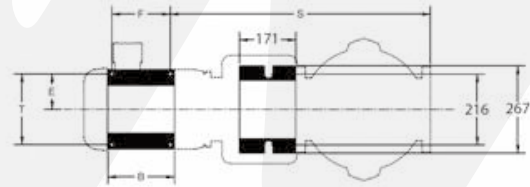

FOOTPRINT DETAIL

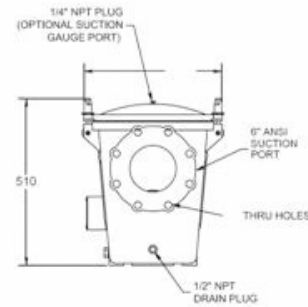
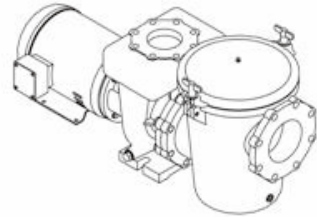
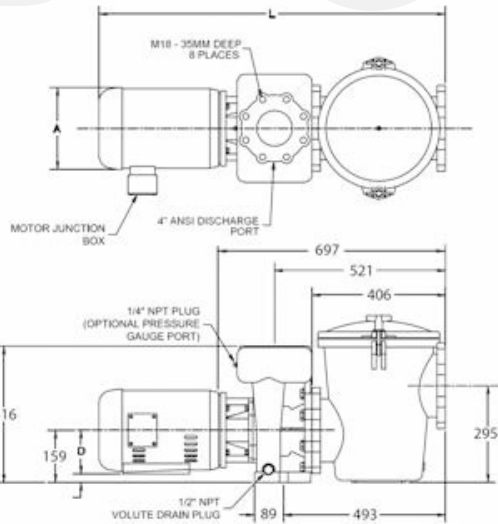

Dimensions - all in mm

	A	B	D	E	F	L	R	S	T	W
4kW	210	180	112	95	140	987	48	727	190	657
5.5kW	270	180	132	110	140	1050	28	749	220	660
7.5kW	270	180	132	110	140	1050	28	749	220	660
9.5kW	260	220	132	110	180	1108	28	777	220	688
11kW	260	220	132	110	180	1108	28	777	220	688

WARRANTY

⚠ WARNING

Waterco Commercial pumps are covered by a comprehensive 1 year warranty for commercial installations. Please consult the Waterco Warranty Terms & Conditions booklet included with the pump for further information.